

MINI MISTRAL R

Mini Mistral R è un apparecchio da incasso in alluminio anodizzato o in acciaio Inox AISI316L con grado di protezione sul frontale IP56, con forma Rotonda. E' dotato di vetro anteriore e lenti che permettono diverse aperture di fascio.

Mini Mistral R is a recessed fixture either with aluminum anodized frontal side or made out of INOX AISI316L, with a IP56 protection degree on the front, with a Rounded shape. It is equipped with front glass and lenses that allow different beam openings.

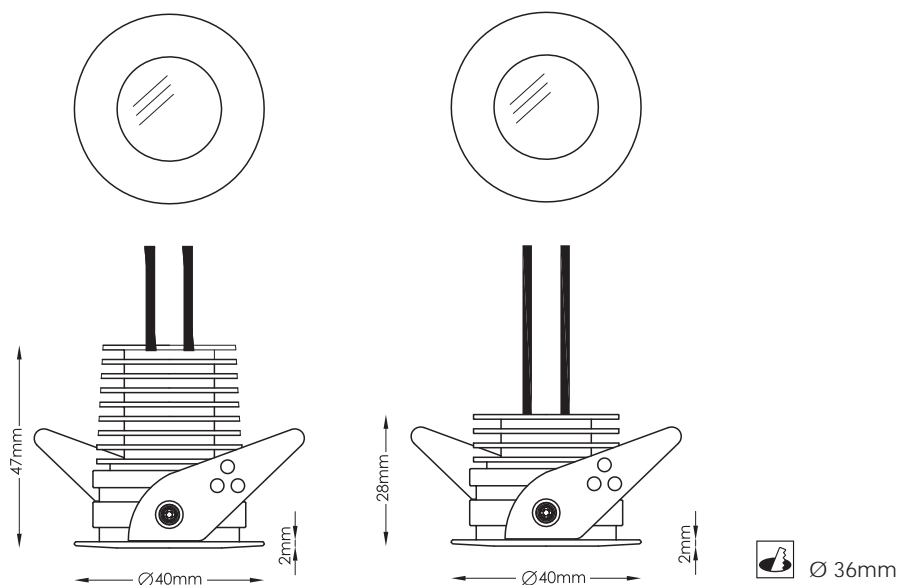

NUMERO LED/NUMBER LEDS - WHITE	1
FLUSSO/FLUX WHITE@350mA	100 Lm@2700K 110 Lm@3000K 110 Lm@4000K (a richiesta/upon request)
FLUSSO/FLUX WHITE@700mA	200 Lm@2700K 220 Lm@3000K 220 Lm@4000K (a richiesta/upon request)
POTENZA/POWER @350mA 24Vdc	1,2W@24Vdc
POTENZA/POWER @700mA 24Vdc	2,4W@24Vdc
TEMPERATURA AMBIENTE DI ESERCIZIO/OPERATING AMBIENT TEMPERATURE	-20°C/45°C
GESTIONE TEMPERATURA LED/ON BOARD ELECTRONICS	si/yes
DIMMERABILITA' /DIMMING	si, con segnale 24Vdc PWM/ yes, with 24Vdc PWM signal
CLASSE DI ISOLAMENTO/INSULATION CLASS	3
TIPO LENTE PRIMARIA/PRIMARY LENS	TIR
APERTURA ANGOLARE/VIEWING ANGLE	10°/20° / 40° / 10°x45°
GRADO IP/IP GRADE	43/56

TABELLA DI SELEZIONE/SELECTION TABLE

CODICE/CODE	ELETTRONICA/ ELECTRONICS	LENTE/LENS	COLORE LED/ LED COLOUR	FINITURA/FINISHING
260	700mA 11 350mA 12	10° 01	2700K 1	Matt white 02
		20° 02	3000K 2	Matt black 03
	40° 03	(4000K) 3	Gold 04	
	10°x45° 04		Chrome 05	
			Bronze 06	
			Custom C	



10° @350mA

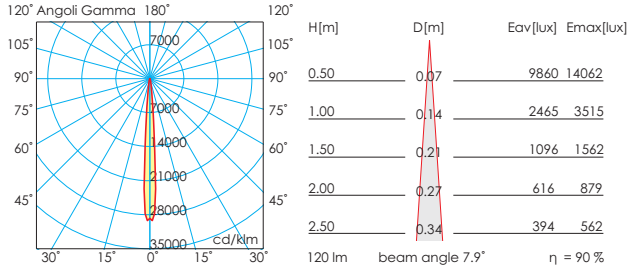

10° @700mA

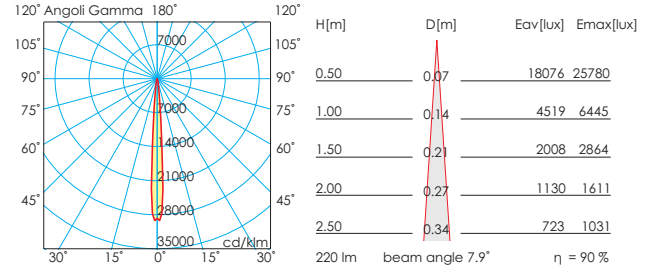

20° @350mA

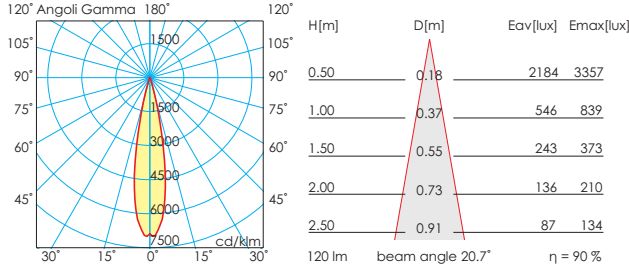

20° @700mA

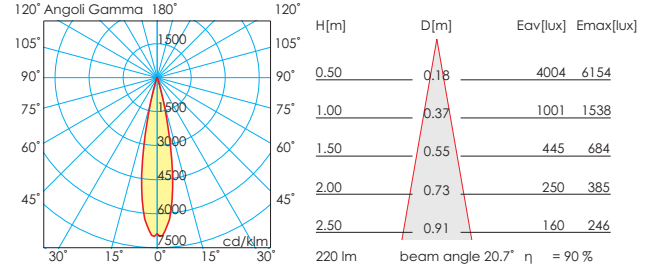

40° @350mA

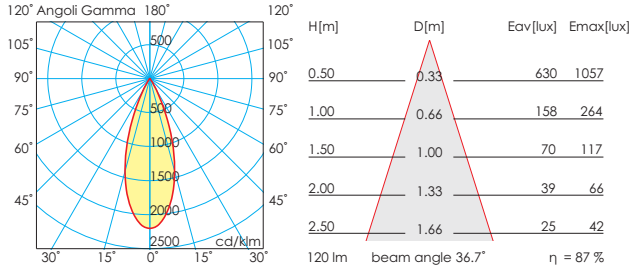

40° @700mA

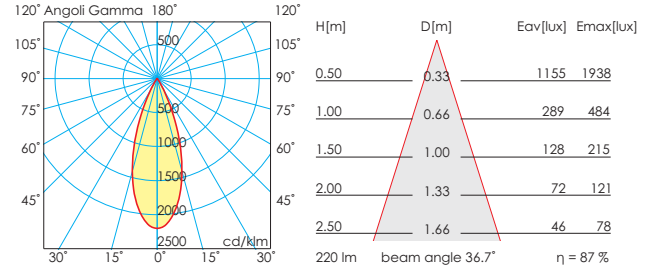

10°x45° @350mA

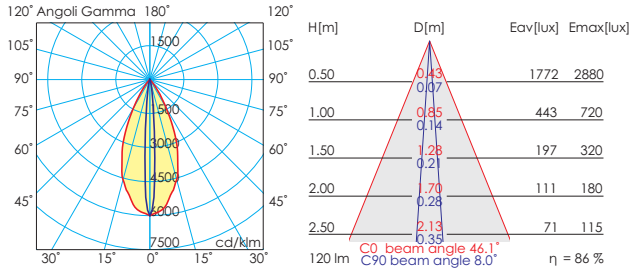

10°x45° @700mA

